

## Warewashing

### EFT1 - 1 Tank

### Flight Type Dishwasher





**Warewashing**

**EFT1 - 1 Tank**

**Flight Type Dishwasher**

510700 (EFT1)      Single Tank Flight Type  
 Dishwasher 400V/3N/50 Hz.

**Standard Features**

Item No. \_\_\_\_\_

Electronic control of all temperatures, statistics and alarms with read out display.  
 Pumped rinse (Duo Rinse) uses fresh final rinse water twice.  
 Drying tunnel (1.100 mm) with inspection door.  
 Water consumption of 320 liters per hour.  
 Insulated doors with safety switch guarantee that the machine cannot be operated with the doors open.  
 Energy saving auto start ensures that the machine is only operated when crockery is loaded.  
 Charging hole 660 mm wide and 420 mm clearance, effective conveyor width of 600 mm.  
 Conveyor belt operated with 2 speeds with automatic overload protection.  
 Large loading section (700 mm) to facilitate the loading of tableware.  
 Unloading section (700 mm) with an automatic conveyor stop, avoids damage to clean items if not removed in time.

**Direction of Operation:**

- 
- Right to Left
- 
- Left to Right

**Version:**

- 
- Electric
- 
- Steam

**OPTIONS AT EXTRA COST**
**Different loading section:**

- 
- 1.100 mm
- 
- 1.500 mm
- 
- 1.800 mm
- 
- 
- 2.400 mm
- 
- 3.000 mm
- 
- 4.000 mm
- 
- 
- 2.900 mm Cross-over

**Different unloading section:**

- 
- 1.100 mm
- 
- 1.500 mm
- 
- 1.800 mm
- 
- 
- 2.400 mm
- 
- 3.000 mm
- 
- 4.000 mm

**Other types of conveyor:**

- 
- Multi-purpose conveyor
- 
- 
- Multi-purpose conveyor with blue plastic sticks
- 
- 
- Conveyor for insulated trays (Temp-Rite and Aladin)
- 
- 
- Conveyor for insulated trays (MDS and Rieber)
- 
- 
- Conveyor for small items
- 
- 
- Conveyor for big items (shall be specified)

**Other features:**

- 
- Condensing unit (Energy saving device)
- 
- 
- Energy Saving Device + Water heat exchanger
- 
- 
- Heat pump
- 
- 
- Stainless steel pump
- 
- 
- 400 mm neutral section
- 
- (dimension of item LxWxH \_\_\_\_\_ mm)
- 
- 
- 600 mm neutral section
- 
- (dimension of item LxWxH \_\_\_\_\_ mm)
- 
- 
- Variable speed with 3 speed switch (DIN 10510)
- 
- 
- Variable wash pressure
- 
- 
- Side wash arms
- 
- 
- Sloping belt (4° slightly towards the back)
- 
- 
- Additional dryer (1.100 mm)
- 
- 
- Rinse booster pump with integrated Air gap
- 
- 
- Thermo disinfection
- 
- 
- Sanitization cycle
- 
- 
- Reversible conveyor
- 
- 
- Strainer from side in loading section
- 
- 
- Other voltages (400V/3N/50Hz standard)
- 
- 
- Split of machine for delivery,
- 
- max length \_\_\_\_\_ mm

*Note: limitations may exist when combining all the above options - consult an Electrolux representative.*



Approval: \_\_\_\_\_

## Functional Zones:

- The water in the main wash tank is pumped with detergent and is sprayed over the items from both the upper and the lower wash arms, guaranteeing a uniform distribution of the washing solution and allowing all the areas of the washing chamber to be covered. An option of variable pressure gives the possibility to increase up to 30% the pressure towards the lower wash arms and at the same time to slow down the belt speed in order to better wash boxes or heavily soiled items.
- Rinse area equipped with the DUO-rinse system: the first rinse arm is filled with re-circulated rinse water to eliminate any trace of detergent, while the second ramp is filled with hot clean water to guarantee the sanitation of the items.
- A drying section with inspection door (1100 mm wide) will be provided as an integral part of the machine. This allows the operator to remove practically dried items immediately, without them being too hot to handle.
- Optional Energy Saving Device (ESD) utilizes heat and steam generated from the machine to pre-heat the incoming water. This reduces energy consumption by 13 kWh by eliminating the need for an external boiler or water heater and allows the machine to be supplied with cold water up to 10° C. In addition, the double pipe in the optional Water Heat Exchanger will have a further energy saving of about 2 kWh as a result of the exchange in temperature between the used rinse water and the incoming fresh water.  
Thanks to the Energy Saving Device, the outgoing air from the machine will be cooler and less humid, eliminating the need for a ventilation hood, if the incoming water is about 10 °C and the room has frequent air changes or is well ventilated.
- Optional Heat pump operating in conjunction with the Energy Saving Device plus the Water Heat Exchanger, will heat up incoming cold final rinse water up to 65 °C before entering the boiler. The introduction of the Heat pump system allows 19 kWh of energy savings; also the heating element in the boiler can also be reduced by 8kW. The exhaust air will be cooled down to about 15°C with very low humidity so that no ventilation hood is needed over the machine.

## Construction:

- 304 AISI stainless steel frame, door, strainers, wash and rinse arms.
- No legs in loading area (700-1.100 mm).
- Wash tanks in 316 AISI acid proof stainless steel with rounded corners to facilitate cleaning.

- Double-skinned construction and insulated counter balanced doors provide silent operation and low heat emission.
- Wash/rinse arms and filters easy to remove.
- Double tank filters (flat and deep box) cover the entire width of the wash tank.
- Simple service from the front.

## Operation:

- The conveyor belt is driven by means of a gear motor which will be protected against overcharge (as a result of blockage or for any other impediment), by a safety device mounted at the end of the unloading side.
- Individual drain valves for each tank. Drain valves are automatically closed when the door is closed, so there is no risk of tank filling with open drain valves.
- Counter balanced doors with safety switch and easy-to-grip handle.
- The machine incorporates a safety stop switch at the top of the discharge section which will automatically stop the conveyor in case that dishes, trays, containers, etc... have not been removed after cleaning.
- Flat panel with electronic control that, thanks to the auto diagnostic control and the 32 digits window, is able to communicate in every moment, the working conditions of the appliance.
- Electronic control panel incorporates the plug-in connection to link basic and integrated HACCP systems.
- Pre-arrangements for external automatic detergent dispenser.
- Two speeds, a fast speed for normal soiled items and a slow speed for heavily soiled items. As option the machine can be equipped with three variable speed selector: normal speed, slow speed for heavily soiled items and a third speed for 2 minute contact time according to DIN 10510. Each speed is individually adjustable.

**Electric Technical Specifications:**

	<b>EFT 1 - 1 Tank Flight Type Dishwasher</b>
Speed min/max - m/min	0,7/1,4
Capacity baskets/hour 1 <sup>st</sup> /2 <sup>nd</sup> speed	84/168
Capacity dishes/hour 1 <sup>st</sup> /2 <sup>nd</sup> speed	1400/2800
Capacity trays/hour 1 <sup>st</sup> /2 <sup>nd</sup> speed	700/1400
<b>1<sup>st</sup> wash</b>	
Temperature - °C	55-65
Tank capacity - lt.	125
Pump flow - l/min	750
Pump power - kW	2,7
Tank heater - kW	15
<b>Rinsing</b>	
Temperature - °C	80-90
Boiler capacity - lt.	16
Boiler power - kW	18
Rinse water consumption - l/h	320
<b>Drying</b>	
Air temperature - °C	40-65
Fan power - kW	0,55
Heater - kW	9
Fan capacity - m <sup>3</sup> /h	2400
<b>Total power*</b>	
Without energy saving system	45,9
With energy saving device (ESD)	45,9
With ESD and Water heat exchanger	45,9
With Heat pump	42,2
Air emission - m <sup>3</sup> /h	450
<b>Air temperature - °C</b>	
Without energy saving system	45-55
With energy saving device (ESD)	22-25
With ESD and Water heat exchanger	22-25
With Heat pump	15-20
Noise level - dBA	<70
<b>Water supply</b>	
Cold water - °C	10-15
Hot water - °C	50-65
Water hardness - max °dH/ °fH	8/ 14
Pressure - bar	3-9
Relative humidity - %	100

\* The total power may change due to optional equipment.

**Steam Technical Specifications:**

	<b>EFT 1 - 1 Tank Flight Type Dishwasher</b>
Speed min/max - m/min	0,7/1,4
Capacity baskets/hour 1 <sup>st</sup> /2 <sup>nd</sup> speed	84/168
Capacity dishes/hour 1 <sup>st</sup> /2 <sup>nd</sup> speed	1400/2800
Capacity trays/hour 1 <sup>st</sup> /2 <sup>nd</sup> speed	700/1400
<b>1<sup>st</sup> wash</b>	
Temperature - °C	55-65
Tank capacity - lt.	125
Pump flow - l/min	750
Pump power - kW	2,7
Tank heater - kg/hr	24
<b>Rinsing</b>	
Temperature - °C	80-90
Boiler capacity - lt.	16
Boiler power - kg/hr	28,8
Rinse water consumption - l/h	320
<b>Drying</b>	
Air temperature - °C	40-65
Fan power - kW	0,55
Heater - kg/hr	14,4
Fan capacity - m <sup>3</sup> /h	2400
<b>Total power*</b>	
Without energy saving system	3,9
With energy saving device (ESD)	3,9
With ESD and Water heat exchanger	3,9
With Heat pump	8,2
Air emission - m <sup>3</sup> /h	450
<b>Air temperature - °C</b>	
Without energy saving system	45-55
With energy saving device (ESD)	22-25
With ESD and Water heat exchanger	22-25
With Heat pump	15-20
Noise level - dBA	<70
<b>Water supply</b>	
Cold water - °C	10-15
Hot water - °C	50-65
Water hardness - max °dH/ °fH	8/ 14
Pressure - bar	3-9
Relative humidity - %	100

\* The total power may change due to optional equipment.



**Electric or Steam - Right to Left**

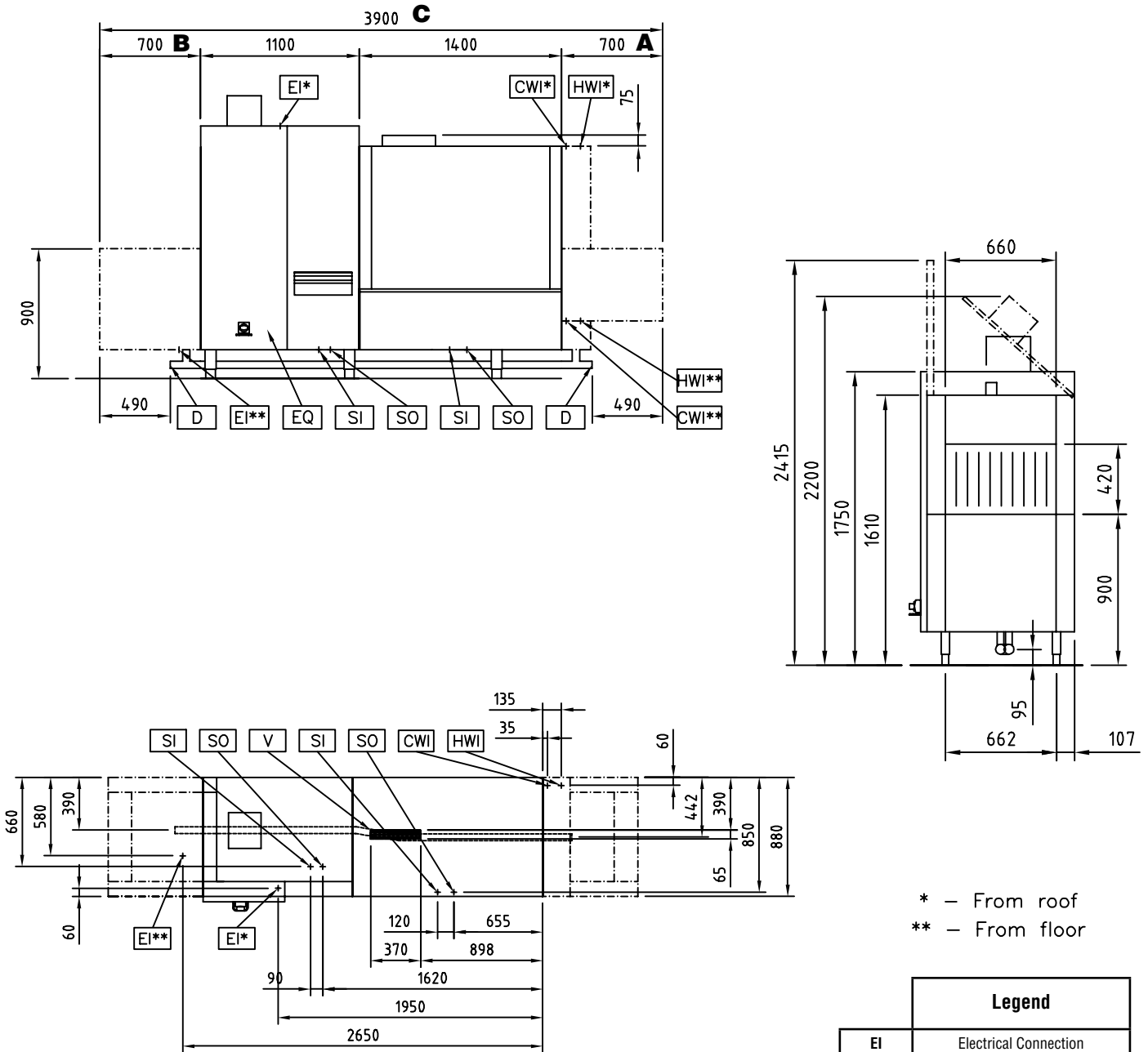

\* - From roof  
\*\* - From floor

Legend	
EI	Electrical Connection
D	Drain
EQ	Equipotential Screw
SI	Steam Inlet
SO	Steam Outlet
V	Vents
HWI	Hot Water Inlet
CWI	Cold Water Inlet

For different loading zone (A), unloading zone (B) and total length (C), please refer to the loading and unloading zone table on the last page.



**Electric or Steam - Left to Right**

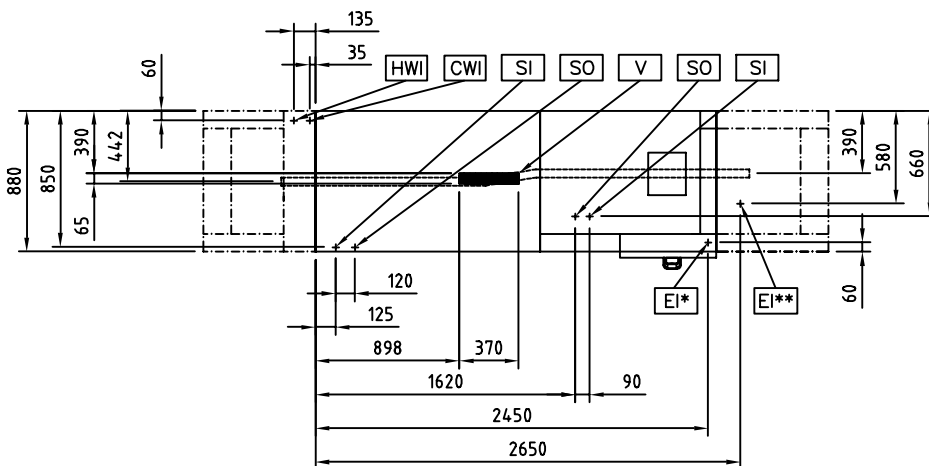
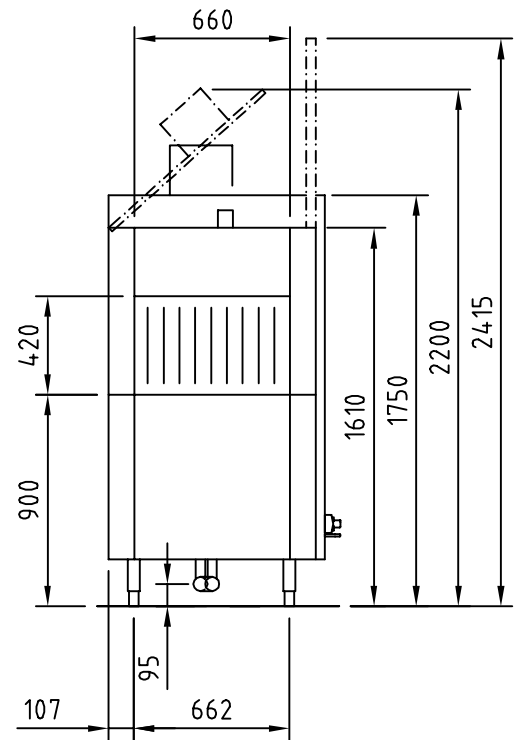
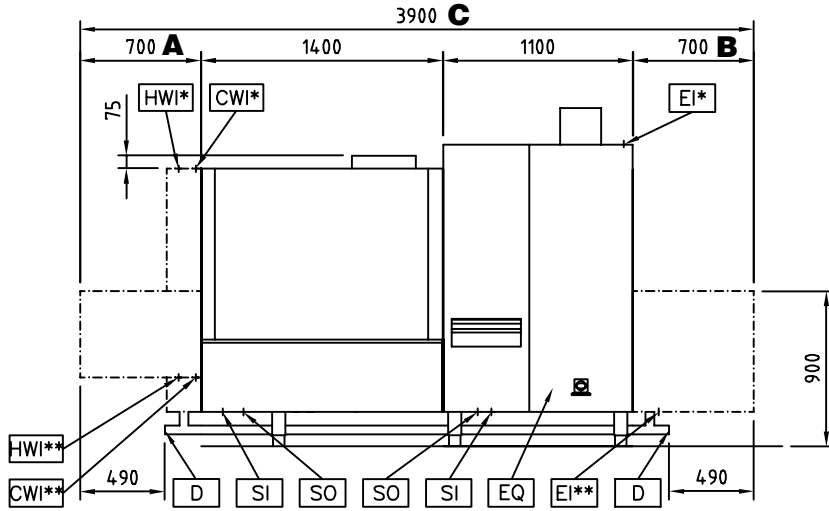

\* - From roof  
\*\* - From floor

Legend	
EI	Electrical Connection
D	Drain
EQ	Equipotential Screw
SI	Steam Inlet
SO	Steam Outlet
V	Vents
HWI	Hot Water Inlet
CWI	Cold Water Inlet

For different loading zone **(A)**, unloading zone **(B)** and total length **(C)**, please refer to the loading and unloading zone table on the last page.

**Overall length of machine with different loading/unloading options:**

		A = Loading size (mm)						
		700	1.100	1.500	1.800	2.400	3.000	4.000
B = Unloading size (mm)	700	3.900	4.300	4.700	5.000	5.600	6.200	7.200
	1.100	4.300	4.700	5.100	5.400	6.000	6.600	7.600
	1.500	4.700	5.100	5.500	5.800	6.400	7.000	8.000
	1.800	5.000	5.400	5.800	6.100	6.700	7.300	8.300
	2.400	5.600	6.000	6.400	6.700	7.300	7.900	8.900
	3.000	6.200	6.600	7.000	7.300	7.900	8.500	9.500

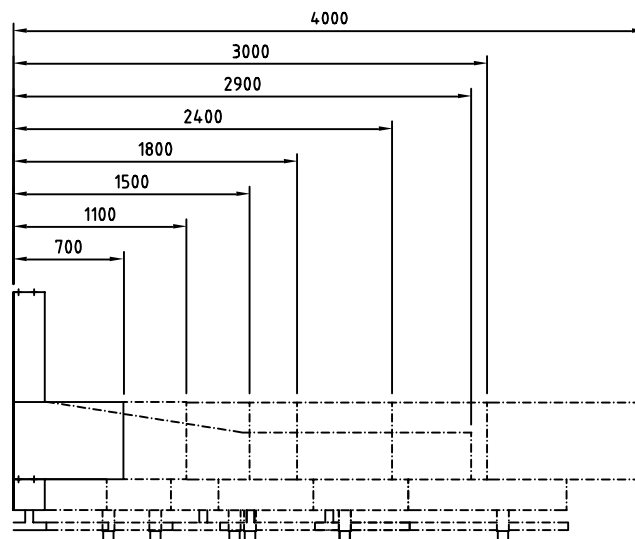
**Loading Zone**

**Unloading Zone**
